



Standard Practice for Ultrasonic Testing Using Electromagnetic Acoustic Transducer (EMAT) Techniques¹

This standard is issued under the fixed designation E1816; the number immediately following the designation indicates the year of original adoption or, in the case of revision, the year of last revision. A number in parentheses indicates the year of last reapproval. A superscript epsilon (ϵ) indicates an editorial change since the last revision or reapproval.

1. Scope*

1.1 This practice covers procedures for the use of electromagnetic acoustic transducers (EMATs) for specific ultrasonic examination applications. Recommendations are given for specific applications for using EMAT techniques to detect flaws through both surface and volumetric examinations as well as to measure thickness.

1.2 These procedures recommend technical details and guidelines for the reliable and reproducible ultrasonic detection of flaws and thickness measurements using electromagnetic acoustic transducers for both the pulsing and receiving of ultrasonic waves. The EMAT techniques described herein can be used as a basis for assessing the serviceability of various components nondestructively, as well as for process control in manufacturing.

1.3 These procedures cover noncontact techniques for coupling ultrasonic energy into materials through the use of electromagnetic fields. Surface, Lamb, longitudinal, and shear wave modes are discussed.

1.4 These procedures are intended to describe specific EMAT applications. These procedures are intended for applications in which the user has determined that the use of EMAT techniques can offer substantial benefits over conventional piezoelectric search units. It is not intended that EMAT techniques should be used in applications in which conventional techniques and applications offer superior benefits (refer to Guide E1774).

1.5 These procedures are applicable to any material in which acoustic waves can be introduced electromagnetically. This includes any material that is either electrically conductive or ferromagnetic.

1.6 The procedures outlined in this practice address proven EMAT techniques for specific applications; they do not purport to address the only variation or all variations of EMAT

techniques to address the given applications. Latitude in application techniques is offered where options are considered appropriate.

1.7 The values stated in inch-pound units are to be regarded as the standard. The values given in parentheses are for information only.

1.8 *This standard does not purport to address all of the safety concerns, if any, associated with its use. It is the responsibility of the user of this standard to establish appropriate safety and health practices and determine the applicability of regulatory limitations prior to use.*

2. Referenced Documents

2.1 ASTM Standards:²

E114 Practice for Ultrasonic Pulse-Echo Straight-Beam Contact Testing

E494 Practice for Measuring Ultrasonic Velocity in Materials

E543 Specification for Agencies Performing Nondestructive Testing

E587 Practice for Ultrasonic Angle-Beam Contact Testing

E797 Practice for Measuring Thickness by Manual Ultrasonic Pulse-Echo Contact Method

E1316 Terminology for Nondestructive Examinations

E1774 Guide for Electromagnetic Acoustic Transducers (EMATs)

2.2 ASNT Standards:³

SNT-TC-1A Recommended Practice for Personnel Qualifications and Certification in Nondestructive Testing

ANSI/ASNT CP-189 Standard for Qualification and Certification of Nondestructive Testing Personnel

2.3 Aerospace Industries Association Standard:

NAS 410 Certification and Qualification of Nondestructive Test Personnel⁴

² For referenced ASTM standards, visit the ASTM website, www.astm.org, or contact ASTM Customer Service at service@astm.org. For *Annual Book of ASTM Standards* volume information, refer to the standard's Document Summary page on the ASTM website.

³ Available from American Society for Nondestructive Testing (ASNT), P.O. Box 28518, 1711 Arlingate Ln., Columbus, OH 43228-0518, <http://www.asnt.org>.

⁴ Available from Aerospace Industries Association of America, Inc. (AIA), 1000 Wilson Blvd., Suite 1700, Arlington, VA 22209-3928, <http://www.aia-aerospace.org>.

*A Summary of Changes section appears at the end of this standard

3. Terminology

3.1 *Definitions:* Related terminology is defined in Terminology E1316.

3.2 *Definitions of Terms Specific to This Standard:*

3.2.1 *bulk wave*—an ultrasonic wave, either longitudinal or shear mode, used in nondestructive testing to interrogate the volume of a material.

3.2.2 *electromagnetic acoustic transducer (EMAT)*— an electromagnetic device for converting electrical energy into acoustical energy in the presence of a magnetic field.

3.2.3 *lift-off effect*—refer to Terminology E1316, Section C.

3.2.4 *Lorentz forces*—forces applied to electric currents when placed in a magnetic field. Lorentz forces are perpendicular to both the direction of the magnetic field and the current direction. Lorentz forces are the forces responsible behind the principle of electric motors.

3.2.5 *magnetostrictive forces*—forces arising from magnetic domain wall movements within a magnetic material during magnetization.

3.2.6 *meander coil*—an EMAT coil consisting of periodic, winding, nonintersecting, and usually evenly spaced conductors.

3.2.7 *pancake (spiral) coil*—an EMAT coil consisting of spirally wound, usually evenly spaced conductors.

4. Summary of Practice

4.1 *Surface Examination:*

4.1.1 The generation of Rayleigh or surface waves in the material to be examined allows for sensitivity to surface flaws and discontinuities. Flaws can be detected by reflections of acoustic waves from the discontinuity interfaces or by acoustic wave attenuation in traversing across the surface of the component. Either pulse-echo or pitch-catch ultrasonic techniques can be used.

4.1.2 Fig. 1 shows a typical EMAT setup for the transduction of Rayleigh or Lamb waves. As shown, an external magnetic induction B is applied parallel to the surface of an electrically conductive or ferromagnetic material. A meander coil is used. The coil is oriented in the same plane as the surface of the material and is excited by an electrical radio frequency (RF) pulse. A surface current is produced in the material by transformer action. The surface current, in the presence of the magnetic field, experiences Lorentz forces that

produce oscillating stress waves perpendicular to the surface of the material to produce surface acoustic waves. Basic EMAT designs generate bidirectional surface waves. Specialized designs can be used to generate unidirectional waves, as with conventional ultrasonic examination.

4.1.3 Surface flaws or discontinuities lead to reflections or attenuation of the surface waves. Upon approach to the receiver EMAT, the reflected or attenuated ultrasonic waves produce oscillations within the conductor in the presence of the magnetic field and thus produce a voltage induction in the coil, allowing for detection.

4.2 *Volumetric Examination:*

4.2.1 Sensitivity to flaws or discontinuities within a part requires the use of bulk acoustic wave modes to interrogate the volume of the material. As with surface examinations, reliance on the reflection or attenuation of acoustic waves from discontinuity interfaces forms the basis for the detection of flaws.

4.2.2 Depending on the particular application, either longitudinal or shear wave modes may be desirable. While straight beam applications using pulse-echo techniques are the most straightforward, angle beam pitch-catch techniques could be desirable, depending on such factors as expected flaw location and orientation.

4.2.3 Fig. 2 shows one typical EMAT setup for the transduction of bulk waves. As shown, an external magnetic induction B is applied normal to the surface of an electrically conductive or ferromagnetic material. A spiral EMAT coil is used for this example. The coil is positioned in a plane parallel to the surface of the material and is excited by an electrical current pulse. A surface current is produced in the material by transformer action. The surface current, in the presence of the magnetic field, experiences Lorentz forces that produce oscillating stress waves originating in the surface of the material. Radially polarized shear waves are generated for this example. Depending on the design characteristics of the magnetic field, the excitation of either radially polarized or planar-polarized shear waves, propagating normal to the surface, can be introduced. Longitudinal wave modes can also be generated and used effectively in non-ferromagnetic materials. Longitudinal wave generation in ferromagnetic materials is impractical due to unacceptably low coupling efficiency. Mode-converted longitudinal waves can be used effectively. Paragraph 7.2 and

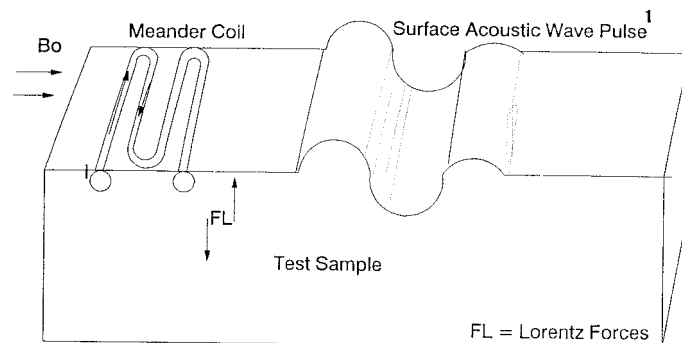

FIG. 1 Typical EMAT Configuration for Rayleigh or Lamb Wave Generation

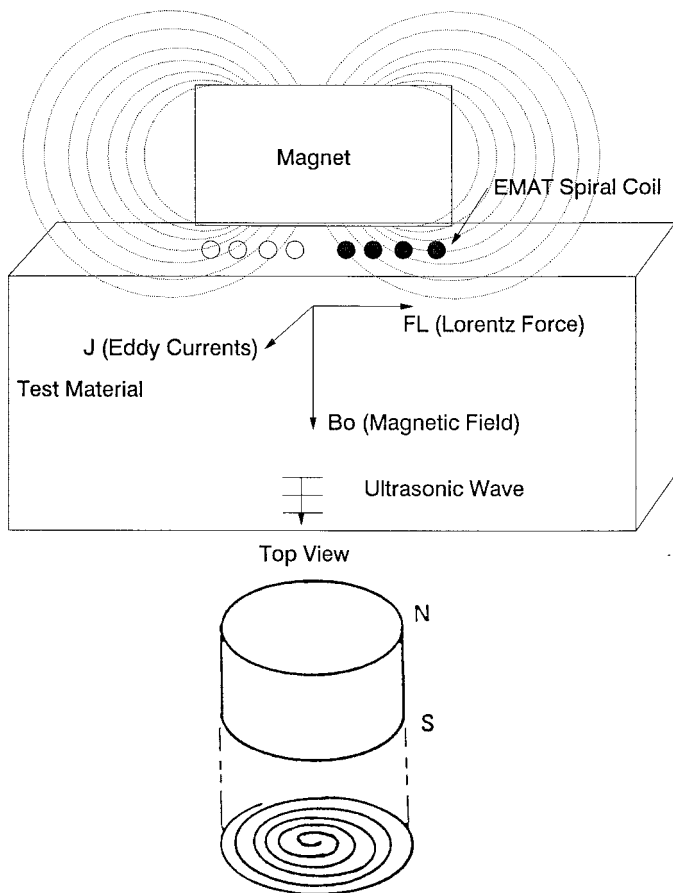

FIG. 2 Typical EMAT Configuration for Bulk Wave Generation

the subparagraphs of 7.2 give a more in-depth discussion of the various EMAT/magnet configurations for producing various bulk wave modes.

4.3 Thickness Gaging:

4.3.1 Determining the thickness of a material by ultrasonic means is a matter of coupling an ultrasonic wave into the material, allowing the sound wave to propagate through the material, reflect from the backwall boundary interface of the material, and propagate back to the front surface. The thickness of the material can be calculated by measuring the transit time of the ultrasonic wave and the knowledge of the ultrasonic wave velocity. Thickness measurements can also be extrapolated for a given material through standardizations of transit time as a function of thickness as derived from a reference block (see Practice E797 and 7.3.1).

4.3.2 The ultrasonic velocity of the material under examination is a function of the physical properties of the material, namely, stiffness and density. It is usually assumed to be constant for a given class of materials. Approximate velocity values are available in tabular format from numerous sources, including the ASNT *Nondestructive Testing Handbook*.⁵ Velocity values can also be determined empirically (see Practice E494).

⁵ *Nondestructive Testing Handbook*, 2nd ed., Vol 7, *Ultrasonic Testing*, A. S. Birks, R. E. Green, and P. McIntire, eds., American Society for Nondestructive Testing, Columbus, OH, 1991.

4.3.3 Determination of the transit time of an acoustic wave through a material requires the use of bulk acoustic wave modes. While longitudinal waves can be used, it is often desirable to use shear waves since their slower propagation velocities lend themselves to more accurate measurements of thin materials. While straight beam applications using pulse-echo techniques are the most straightforward and popular, angle beam pitch-catch techniques could be desirable, especially in applications in which fast scan rates are needed or high resolution is desired for thin material. The generation of bulk waves by means of the EMAT technique is discussed in 4.2.3 and depicted in Fig. 2.

5. Significance and Use

5.1 Since EMAT techniques are noncontacting, they should be considered for ultrasonic examinations in which applications involve automation, high-speed examinations, moving objects, applications in remote or hazardous locations, and applications to objects at elevated temperatures or objects with rough surfaces. This practice describes procedures for using EMAT techniques as associated with the ultrasonic method to detect flaws for both surface and volumetric examinations as well as to measure thickness.

5.2 The uniqueness of the electromagnetic acoustic transducer technique for ultrasonic examination basically lies in the generation and reception of the ultrasonic waves. Otherwise, conventional ultrasonic techniques and methodologies generally apply.

5.3 An EMAT generates and receives acoustic waves in a material by electromagnetic means; electrically conductive or ferromagnetic materials can be examined. In its simplest form, an EMAT as a generator of ultrasonic waves is basically a coil of wire, excited by an alternating current, and placed in a uniform magnetic field near the surface of a material. For conductive materials, eddy currents are induced as a result of the alternating current. Due to the magnetic field, these eddy currents experience Lorentz forces that in turn are transmitted to the solid by collisions with the lattice or other microscopic processes. These forces are alternating at the frequency of the driving current and act as a source of ultrasonic waves. If the material is ferromagnetic, additional coupling mechanisms play a part in the generation of ultrasonic waves. Interactions between the dynamic magnetic field generated by the alternating currents and the magnetization associated with the material offer a source of coupling, as do the associated magnetostrictive influences. Reciprocal processes exist whereby all of these mechanisms lead to detection. Fig. 3 depicts the mechanisms (forces), along with associated direction, for electromagnetic ultrasound generation.

5.4 The EMAT can be used to generate all ultrasonic modes of vibration. As with conventional ultrasonic techniques, material types, probable flaw locations, and flaw orientations determine the selection of beam directions and modes of vibration. The use of EMATs and selection of the proper wave mode presuppose a knowledge of the geometry of the object; the probable location, size, orientation, and reflectivity of the expected flaws; the allowable range of EMAT lift-off; and the laws of physics governing the propagation of ultrasonic waves.

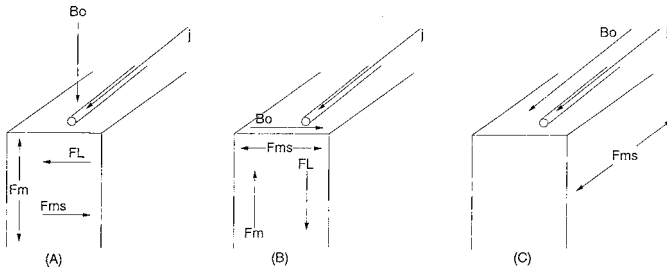

NOTE 1— j = current in a single conductor, B_o = magnetization from external magnet, F_m = magnetic force (ferromagnetic material), F_{ms} = magnetostrictive force (ferromagnetic material), and FL = Lorentz force (conductive material).

FIG. 3 Mechanisms of Electromagnetic Ultrasound Generation

5.5 The EMAT techniques show benefits and advantages over conventional piezoelectric ultrasonic techniques in special applications in which flexibility in the type of wave mode generation is desired. The EMATs are highly efficient in generating surface waves. The EMATs lend themselves to horizontally polarized shear wave (SH) generation more easily than do conventional ultrasonic search units. This is important since SH shear waves produce no mode conversions at interfaces and their angle of introduction can be varied from 0 to 90° simply by sweeping through various frequency RF generation. The EMATs can also be configured to produce Lamb wave modes whose use can provide the full circumferential examination of tubular products or volumetric examination of thin plate material. The EMATs also lend themselves easily to the repeatability of sensor fabrication, and hence the associated sensor response is highly reproducible.

6. Basis of Application

6.1 The following items are subject to contractual agreement between the parties using or referencing this standard.

6.2 Personnel Qualification:

6.2.1 If specified in the contractual agreement, personnel performing examinations to this practice shall be qualified in accordance with a nationally- or internationally-recognized NDT personnel qualification practice or standard such as ANSI/ASNT-CP-189, SNT-TC-1A, NAS-410, or a similar document and certified by the employer or certifying agency, as applicable. The practice or standard used and its applicable revision shall be identified in the contractual agreement between the using parties.

6.3 Qualification of Nondestructive Agencies—If specified in the contractual agreement, NDT agencies shall be qualified and evaluated as described in Specification E543. The applicable edition of Specification E543 shall be specified in the contractual agreement.

6.4 Procedures and Techniques—The procedures and techniques to be used shall be as described in this practice unless otherwise specified. Specific techniques may be specified in the contractual agreement.

6.5 Reporting Criteria and Acceptance Criteria—Reporting criteria for the examination results shall be in accordance with Section 11 unless otherwise specified. Acceptance criteria shall be specified in the contractual agreement.

6.6 Reexamination of Repaired and Re-Worked Items—The reexamination of repaired and reworked items is not addressed in this practice and, if required, shall be specified in the contractual agreement.

7. Apparatus

7.1 Surface Examinations:

7.1.1 Base Material Applications:

7.1.1.1 EMAT Coil Design—Fig. 4 shows a typical meander EMAT coil design for Rayleigh wave transduction. The mode of operation can be either pulse-echo or pitch-catch.

7.1.1.2 Coil Excitation—A high-power, specialized RF generator is necessary to provide excitation to the coil in the form of a toneburst of several cycles.

7.1.1.3 Magnetization—Fig. 5 shows a typical electromagnetic configuration for producing an external magnetic induction for the meander coil. A pulsed magnetic induction is produced parallel to the examination surface for the particular design shown. An accompanying magnet pulser and power supply unit are needed to supply the current pulse to the pulsed magnet. It should be noted that magnetization could be supplied from a permanent magnet or from a dc magnet with power supply.

7.1.1.4 Instrumentation—The following is a description of a typical instrumentation package for data acquisition and analysis of the EMAT signals. The signal processing and data acquisition electronics should consist of a receiver section to provide for adjustable gain and filtering for the EMAT signals. Conventional ultrasonic instruments can be used for this purpose. The user has several options to capture and analyze the EMAT signals. A personal computer housing any of several commercially available analog-to-digital converter boards with associated dedicated ultrasonics software provides for an effective configuration. However, as with conventional ultrasonics, configurations as simple as analog output to oscilloscope can provide for acceptable results. In either case,

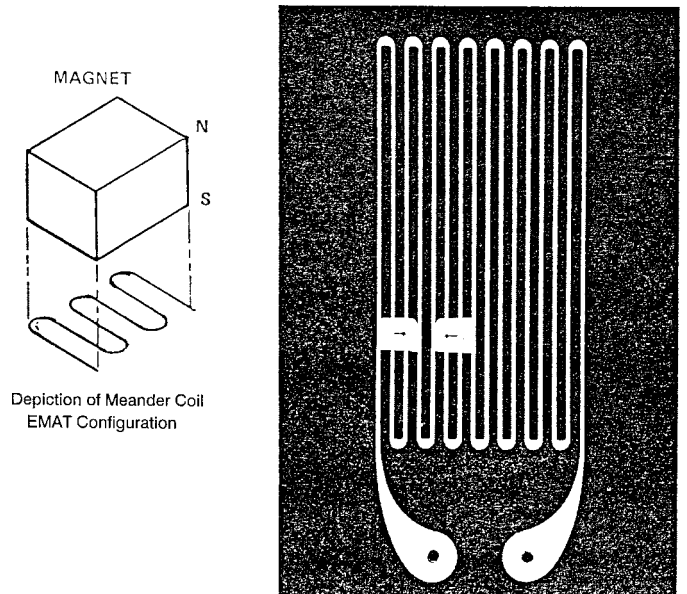

FIG. 4 Typical EMAT Meander Coil for Rayleigh Wave Generation

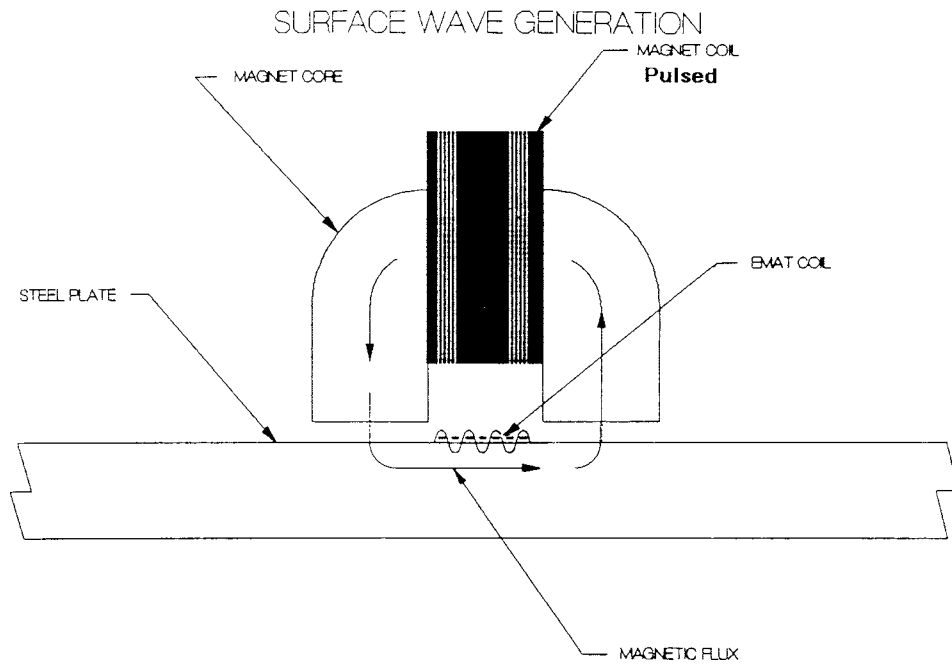

FIG. 5 Typical Electromagnet Configuration for Surface Wave Transduction

pulser/receiver synchronization circuitry will be necessary to provide adequate triggering for signal acquisition.

7.1.1.5 *Reference Standard*—A reference standard for verification of the system standardization should be prepared from a component of the same material, thickness, surface finish, and nominal heat treatment as the material to be examined. The material should be free of discontinuities or other abnormal conditions other than those reference reflectors exemplifying the necessary sensitivity. Flaw dimensions of length, depth, and width must be decided upon by the using party or parties and should be consistent with the acceptance criteria.

7.1.2 *Weld Applications:*

7.1.2.1 *EMAT Coil Design*—In most cases, the EMAT coil/magnet design for base material applications (7.1.1) can be used effectively for weld applications. In certain applications, however, the examination of welds for surface discontinuities presents unique challenges. A problem arises in that the root and crown of the weld can produce reflections that are prominent enough to interfere with, or even obscure, any flaw signals. Through the use of a proven diffraction technique, signals reflected as a result of weld geometry effects can be eliminated while flaw indications can be shown clearly. Fig. 6 shows a specially designed pitch-catch EMAT coil configuration consisting of a collinear set of focused EMAT search units that, when scanned, are rotated at an angle with respect to the weld centerline. The frequency is chosen so that the wavelength of the Rayleigh wave is comparable to the dimensions of the critical surface discontinuities that must be detected. As a result, the surface discontinuities can be detected by diffraction over a wide range of angles, but the root and crown signals are reflected away as specular reflectors.

7.1.2.2 *Coil Excitation*—See 7.1.1.2.

7.1.2.3 *Magnetization*—Fig. 5 shows a typical magnet configuration for producing an external magnetic induction for the specialized coil configuration described in 7.1.2.1. The particu-

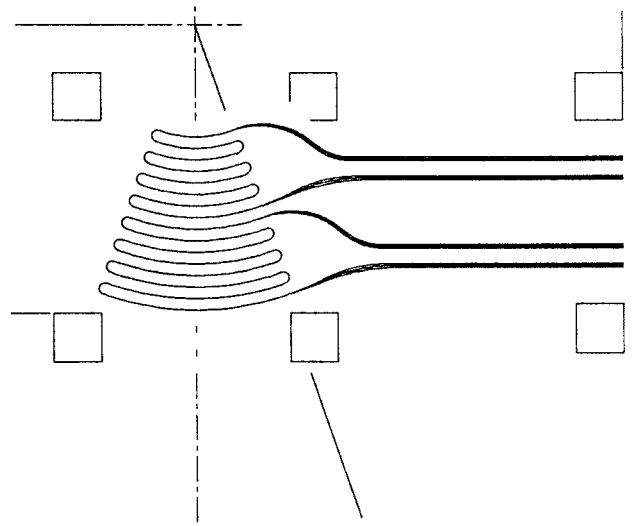

FIG. 6 Collinear-Focused EMAT Coils for Surface Wave Transduction

lar design shown provides for a magnetic induction parallel to the examination surface. Again, permanent or dc electromagnets can also be used to supply the magnetic induction.

7.1.2.4 *Instrumentation*—See 7.1.1.4.

7.1.2.5 *Reference Standard:* (1) A reference standard for verification of the system standardization should be prepared from a length of weldment of the same material, welding magnetic properties, thickness, surface finish, and nominal heat treatment as the material to be examined. The weldment should be free of discontinuities or other abnormal conditions that could cause interference with detection of the reference reflectors. The reference reflectors should be selected to ensure

uniform coverage of the weld at the sensitivity levels prescribed. The reference reflectors most commonly used will consist of machined notches or flat-bottom holes.

(2) Reference reflectors may be placed in the weld seam, in the base material heat-affected zone of the weld, or in the material parallel to the weld seam, as specified in the weld acceptance criteria.

(3) The machined notch dimensions of length, depth, and width must be decided upon by the using party or parties and should be consistent with the weld acceptance criteria.

(4) The notch depth should be measured from the adjacent surface to its maximum and minimum penetration. Measurements may be made by optical, replicating, mechanical, or other techniques. Notch depth is commonly specified as a percent of nominal material thickness.

7.2 Volumetric Examination:

7.2.1 Base Material Applications:

7.2.1.1 EMAT Coil Design—For volumetric examinations, the use of bulk acoustic waves is appropriate for interrogation of the volume of a material. Fig. 7 shows various EMAT coil/magnet configurations for bulk wave transduction. Modes of operation can be either pulse-echo or pitch-catch, as with conventional ultrasonics. Coil excitation is provided by an RF pulse. As shown, magnetic induction can be either parallel or normal to the sample surface, depending on the desired wave mode.

7.2.1.2 Coil Excitation—A high-power, specialized RF generator is necessary to provide coil excitation. If the specific EMAT coil is of the meander type, a toneburst of several cycles is the required RF pulse type. A high-power spike pulse or short-duration toneburst is required if the spiral coil is used.

7.2.1.3 Instrumentation—See 7.1.1.4.

7.2.1.4 Reference Standard—See 7.1.1.5.

7.2.2 Weld Applications:

7.2.2.1 EMAT Coil Design—The EMAT coil design for volumetric weld examinations is basically the same as that used for volumetric examinations of the base material, and, therefore, the EMAT coil/magnet configurations shown in Fig. 7 apply. Again, the mode of operation can be either pulse-echo or pitch-catch. Coil excitation is provided by an RF pulse. Magnetization can be either parallel or normal to the sample surface, depending on the particular wave modes desired.

7.2.2.2 Coil Excitation—See 7.2.1.2.

7.2.2.3 Instrumentation—See 7.1.1.4.

7.2.2.4 Reference Standard: (1) A reference standard for verification of the system standardization should be prepared from a length of weldment of the same material, thickness, surface finish, and nominal heat treatment as the material to be examined. The weldment should be free of discontinuities or other abnormal conditions that could cause interference with detection of the reference reflectors. The reference reflectors should be selected to ensure uniform coverage of the weld at

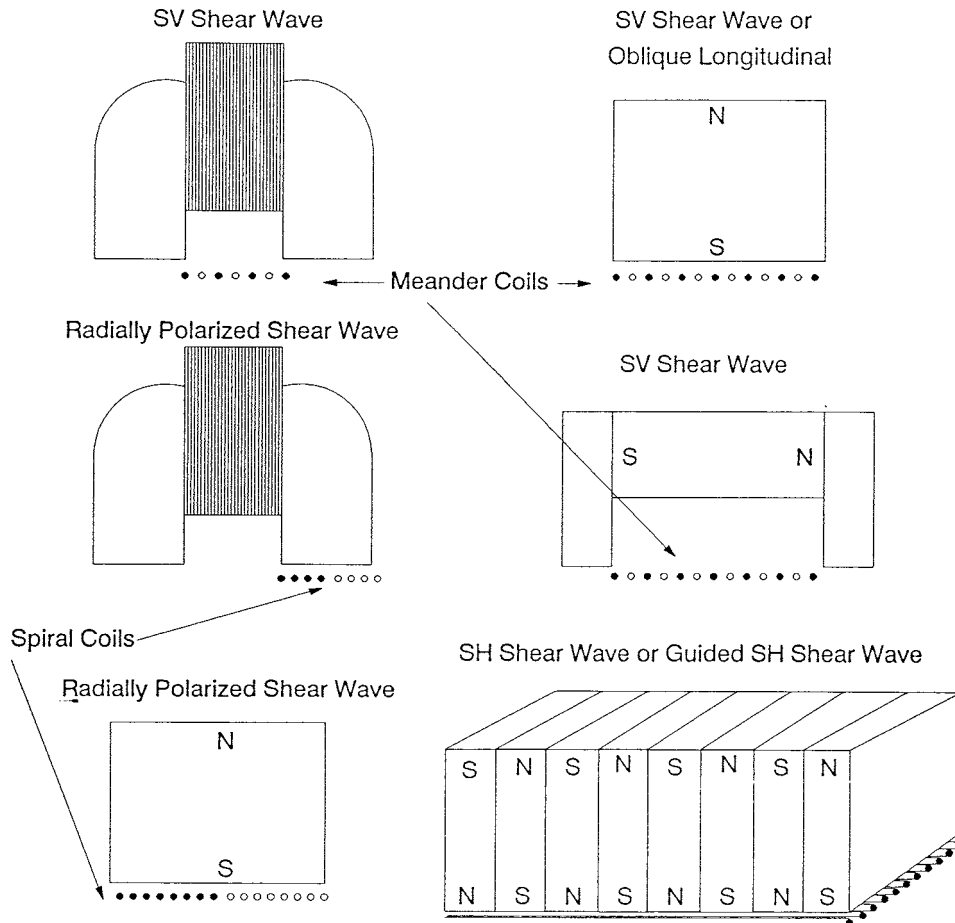

FIG. 7 Typical EMAT Coil/Magnet Configurations for Bulk Waves

the sensitivity levels prescribed. The reference reflectors most commonly used will consist of machined notches or drilled flat-bottom holes.

(2) Reference reflectors may be placed in the weld seam, in the base material heat-affected zone of the weld, or in the material parallel to the weld seam, as specified in the weld acceptance criteria.

(3) The machined notch dimensions of length, depth, and width, or hole diameter and depth, must be decided upon by the using party or parties and should be consistent with the weld acceptance criteria.

(4) The notch or hole depth should be measured from the adjacent surface to its maximum and minimum penetration. Measurements may be made by optical, replicating, mechanical, or other techniques. Notch or hole depth is commonly specified as a percent of nominal material thickness.

7.3 Thickness Gaging:

7.3.1 *Thin Components*—The following EMAT procedure is recommended for measuring the thickness in components ranging from 0.100 to 0.500 in. (2.54 to 12.7 mm) and expressly for components exhibiting relatively rough back surfaces.

7.3.1.1 *EMAT Design*—Fig. 8 shows an effective EMAT coil design for measuring thickness in thin components. The particular design shown incorporates a pitch-catch configuration. It is used to introduce a shear wave into the component and receive a reflected longitudinal mode from the back surface. Coil excitation is from a large current spike pulse. This particular design offers advantages over typical pulse-echo techniques. The angularly reflected and mode-converted longitudinal wave effectively introduces a delay that reduces or eliminates problems with “main-bang spill-over” into the first reflection and simultaneously allows the use of lower-frequency analysis (that is, roughly 1 MHz), which is less sensitive to any back surface irregularities. This technique effectively allows the use of the first back wall reflection, a procedure that is imperative to ensure accurate results for applications in which the back surface is irregular (for example, steam or distribution tubing).

7.3.1.2 *Coil Excitation*—A high-power, specialized RF generator is necessary to provide excitation to the coil in the form of a spike pulse or short-duration toneburst.

7.3.1.3 *Magnetization*—Fig. 5 depicts a pulsed electromagnet design that can be used to produce the magnetic field for the coil described in 7.3.1.1. The pulsed magnet generates tangential magnetic fields in the surface of the component. An

accompanying magnet pulser and power supply unit are necessary to supply the current pulse to the pulsed magnet. Permanent or dc electromagnets could also be used to produce the magnetic induction.

7.3.1.4 *Instrumentation*—The following is a description of a field-tested instrumentation package associated with the thickness gaging application described above. The signal processing and data acquisition electronics consist of a receiver section, a ruggedized personal computer (PC), a waveform digitizing board, and synchronization circuitry. A receiver section from a commercially available ultrasonic testing device can be used to provide adjustable gain and filtering for the EMAT signals. A PC section using any of several commercially available analog-to-digital (A/D) boards can be used to capture the received EMAT signals. Commercially available, or slightly modified commercially available, software can provide the necessary programming capability to measure the time of arrivals and amplitude of the EMAT signals as well as display the A-scan and thickness data. Any conventional ultrasonic thickness measurement instrumentation, properly configured, should also produce adequate results.

7.3.1.5 *Reference Standard*—For verification of the system standardization, a reference standard of known thickness should be prepared from a component of the same material, surface finish, and nominal heat treatment as the material to be examined. The material should be free of discontinuities or other abnormal conditions.

7.3.2 *Thick Components:*

7.3.2.1 *EMAT Design*—For thickness measurements in relatively thick components approximately 0.250 in. (6.35 mm), a pancake coil design, as depicted in Fig. 9, is most commonly used. The particular design shown incorporates a pulse-echo configuration. It is used to introduce a shear wave into the component and monitor its reflection from the back surface. Coil excitation is from a large current spike pulse.

7.3.2.2 *Coil Excitation*—See 7.3.1.2.

7.3.2.3 *Magnetization*—Fig. 10 depicts the magnet design used to produce the magnetic field for the coil described in 7.3.2.1. The magnet generates normal magnetic fields in the surface of the component.

7.3.2.4 *Instrumentation*—See 7.3.1.5.

7.3.2.5 *Reference Standard*—See 7.3.1.4.

8. Standardization

8.1 Since EMATs are not generally commercially available, as are conventional piezoelectric ultrasonic search units, it is



FIG. 8 Pitch-Catch EMAT Coil Configuration for Thickness Measurements in Thin Components

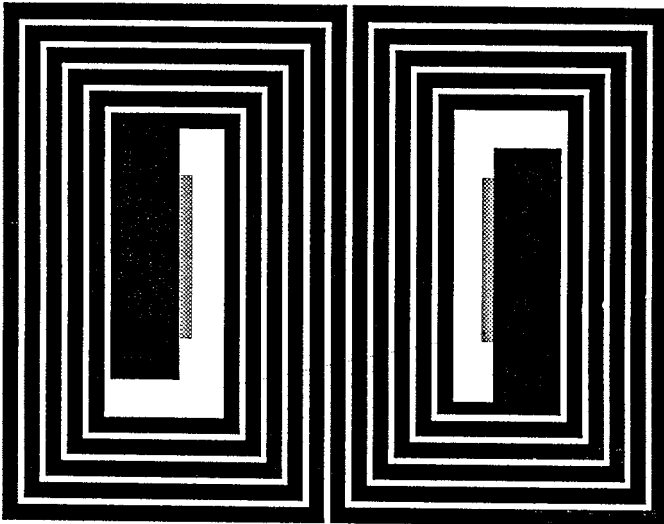

FIG. 9 Typical EMAT Pancake Coil for Thickness Measurements in Thick Components

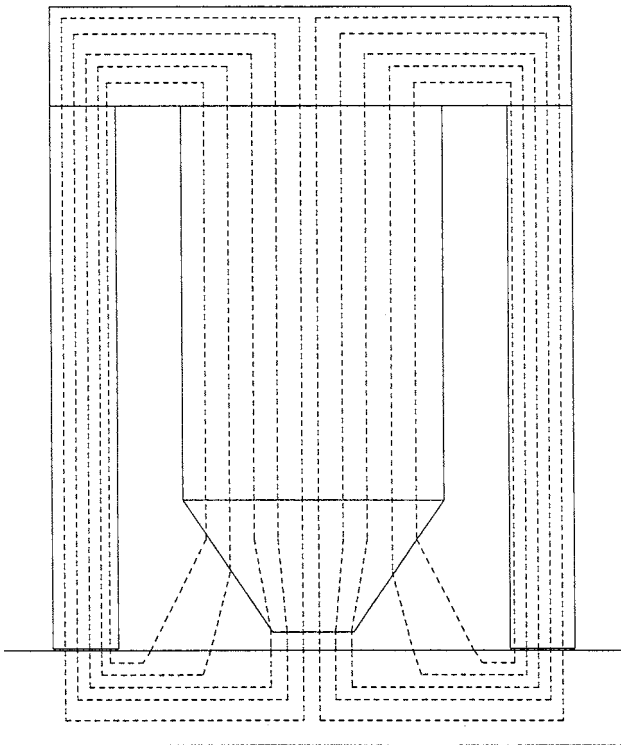

FIG. 10 Permanent Magnet Design for EMAT Pancake Coil in Fig. 9

the responsibility of the designer to ensure that the EMAT configurations demonstrate the specified sensitivity and frequency characteristics prior to their initial use. Thereafter, it is adequate to standardize the EMAT system as a unit with regard to the response from reference standards alone.

8.2 Prior to examination, it is recommended that the EMAT system be standardized by means of ASTM or other reference blocks, as specified in the contractual specification.

8.3 Reference standards should have ultrasonic characteristics similar to the material being examined and, more specifically, should be selected as described in Section 7 for the specific applications.

8.4 As in conventional ultrasonic application, attenuation correction should be completed if the amplitude of a reference reflector (for example, backwall) in the reference standard does not match that of the sample.

8.5 Reference standards should be rechecked following any system or operator changes to maintain standardization.

8.6 During operation, the system should be standardized every 4 h of operation, or as contractually agreed upon, to ensure that the EMAT system accuracy is being maintained. The equipment should be adjusted anytime that a signal varies by 10 % or more from that established initially from the reference standard.

8.7 If the EMATs are being operated in a scan mode of operation, it should be verified that the scan rates are conducive with electronic digitizing rates to ensure ultrasonic resolution adequate to the specified contract.

8.8 Unless otherwise specified, the EMAT system should always provide for an A-scan display option. As a minimum, the initial pulse and one back wall reflection should be present on the oscilloscope trace. The total number of visible reflections depends on operator preference.

8.9 Specific standardization procedures should be generated for specific applications. Generic procedures for both flaw and thickness applications are outlined as follows.

8.10 *Thickness Applications:*

8.10.1 *Reference Block Selection*—As a minimum, the reference block or blocks shall have two thicknesses. One thickness should be within 10 % of the minimum thickness expected from the actual sample(s). The other thickness should be within 10 % of the maximum thickness expected from the sample(s). It is recommended that reference blocks also be available representing thicknesses between the maximum and minimum values. The EMATs shall be placed on the selected reference block and the instrumentation parameters adjusted until appropriate thicknesses are displayed.

8.10.2 Since the major difference between examinations with EMATs and those with conventional ultrasonics lies in the coupling mechanism, standardization guidance from conventional ultrasonic thickness procedures should be used, as appropriate (for example, Practice E797).

8.10.3 *Back Reflection Amplitude*—The amplitude of the back wall reflection should be monitored to ensure that adequate signal strength is available for accurate thickness measurements and to ensure that adequate electromagnetic coupling is being maintained.

8.10.4 *Back Reflection Gating*—Gating for the back wall reflection should be verified prior to examining and periodically thereafter to ensure that the proper gating location and length are being maintained to ensure the accuracy of examination.

8.11 *Flaw Detection:*

8.11.1 *Reference Block Selection*—The reference blocks should have the size and type of reference reflectors specified in the contractual agreement. Equipment adjustments shall be made to produce clearly identifiable indications to verify the sensitivity.

8.11.2 Since the major difference between examinations with EMATs and those with conventional ultrasonics lies in the coupling mechanism, standardization guidance from conventional ultrasonic thickness procedures should be used. If accurate locations of reflectors are desired, standardization should follow the procedures outlined in Practice E587, as applicable, for longitudinal, shear, surface, or Lamb wave mode utilization.

9. Procedure

9.1 *Surface Examination:*

9.1.1 The procedure outlined herein describes an EMAT technique for the application of detecting surface discontinuities in components. While it is not purported to be the only applicable technique, it does describe a field-tested proven methodology.

9.1.2 All surfaces of the examination components should be relatively free of scale, dirt, burrs, slag, spatter, or other conditions that could interfere with the examination results or damage the EMAT probe.

9.1.3 To examine the surface of a weld or base material, the operator places the EMAT probe head on the object to be examined. If a pulsed electromagnet is being used for the magnetic induction, a current pulse from a magnet pulser is then initiated. After a short time delay, to allow the magnetic field to build to an acceptable level, the pulsed magnet electronics send a trigger pulse to the synchronizer circuit located in the signal processing electronics. Coincident with a leading edge of the digitizer clock, a triggering pulse is sent to the EMAT coil pulser in the probe head to trigger the digitizer board. A tone burst pulse is generated in the transmit EMAT coil, which, in the presence of the applied magnetic field, launches an ultrasonic surface wave. It should be noted that either a dc electromagnet or a permanent magnet could also be used to supply the magnetic induction.

9.1.4 The Rayleigh wave then traverses across the surface of the component and is reflected by the presence of any surface-breaking discontinuity. The reflected wave is then detected by the receiver EMAT coil, either the same coil in a pulse-echo configuration or a separate coil in a pitch-catch configuration. It should be noted that surface wave attenuation techniques have also been used successfully for surface examinations.

9.1.5 The signal voltage from the receiver EMAT coil is amplified by a low-noise preamplifier and sent to the receiver section in the signal processing electronics, where it is further amplified, filtered, and sent to the waveform digitizer board. The detection of a discontinuity is indicated by the presence of a reflector in the digitized signal. The process is repeated for scan mode at fixed time intervals, and discontinuity presence is indicated by tracking the reflected signal amplitude and time of flight.

9.1.6 Periodically check the sensitivity of the equipment by scanning the reference standard. Make these checks prior to any examination, prior to equipment shutdown after examination, and at least every 4 h during continuous equipment operation. Adjust the equipment anytime that a signal varies in sensitivity by 10 % or more from that established initially from the reference standard.

9.2 *Volumetric Examination:*

9.2.1 The procedure outlined herein describes an EMAT technique for the application of detecting volumetric discontinuities in components through the use of bulk acoustic waves. While it is not purported to be the only applicable technique, it does describe a field-tested proven methodology.

9.2.2 All surfaces of the examination components should be relatively free of scale, dirt, burrs, slag, spatter, or other conditions that could interfere with the examination results or damage the EMAT probe.

9.2.3 To detect volumetric discontinuities in a weld, weldment, or component, the operator places the EMAT probe head on the object to be examined. A trigger pulse is sent to the synchronizer circuit located in the signal processing electronics. Coincident with a leading edge of the digitizer clock, a triggering pulse is sent to the EMAT coil pulser in the probe head to trigger the digitizer board. A tone burst pulse is generated in the transmit EMAT coil, which, in the presence of the applied magnetic field, launches an ultrasonic shear wave.

9.2.4 The shear wave then traverses through the volume of the component and is reflected by the presence of any included discontinuity. The reflected wave is then detected by the receiver EMAT coil, either the same coil in a pulse-echo configuration or a separate coil in a pitch-catch configuration.

9.2.5 The signal voltage from the receiver EMAT coil is amplified by a low-noise preamplifier and sent to the receiver section in the signal processing electronics, where it is further amplified, filtered, and sent to the waveform digitizer board. The detection of a discontinuity is indicated by the presence of a reflector in the digitized signal. The process is repeated for scan mode at fixed time intervals, and defect presence is indicated by tracking the reflected signal amplitude and time of flight.

9.2.6 Periodically check the sensitivity of the equipment by scanning the reference standard. Make these checks prior to any examination, prior to equipment shutdown after examination, and at least every 4 h during continuous equipment operation. Adjust the equipment anytime that a signal varies in sensitivity by 10 % or more from that established initially with the reference standard.

9.3 *Thickness Gaging:*

9.3.1 *Thin Components:*

9.3.1.1 The procedure outlined herein describes one EMAT technique for the application of measuring material thickness in thin components ranging from 0.100 to 0.500 in. (2.54 to 12.7 mm). While it is not purported to be the only applicable technique, it does describe a field-tested proven methodology for application to fast scanning of tubing.

9.3.1.2 All surfaces of the examination components should be relatively free of scale, dirt, burrs, slag, spatter, or other

conditions that could interfere with the examination results or damage the EMAT probe.

9.3.1.3 To make a thickness measurement or scan, the operator places the EMAT probe head on the object to be examined. The current pulse from the magnet pulser is then initiated. After a short time delay, to allow the magnetic field to build to an acceptable level, the pulsed magnet electronics send a trigger pulse to the synchronizer circuit located in the signal processing electronics. Coincident with a leading edge of the digitizer clock, a triggering pulse is sent to the EMAT coil pulser in the probe head to trigger the digitizer board. A large current spike pulse is generated in the transmit EMAT coil, which, in the presence of the applied magnetic field, launches an ultrasonic shear wave.

9.3.1.4 The shear wave is reflected at the back surface interface and mode converted to include a longitudinal vibrational component. This longitudinal wave is then detected by the receiver EMAT coil.

9.3.1.5 The voltage from the receiver EMAT coil is amplified by a low-noise preamplifier and sent to the receiver section in the signal processing electronics, where it is further amplified, filtered, and sent to the waveform digitizer board. The time-of-arrival and amplitude of the digitized signal is measured and used to compute the wall thickness using computer software. The process is repeated for scan mode at fixed time intervals.

9.3.1.6 Periodically check the sensitivity of the equipment by scanning the reference standard. Make these checks prior to any examination, prior to equipment shutdown after examination, and at least every 4 h during continuous equipment operation. Adjust the equipment anytime that a signal varies in sensitivity by 10 % or more from that established initially with regard to the reference standard.

9.3.2 *Thick Components:*

9.3.2.1 The procedure outlined herein describes one EMAT technique for the application of measuring material thickness in components 0.250 in. (6.35 mm) and thicker. While it is not purported to be the only applicable technique, it does describe a field-tested proven methodology for application to fast scanning of tubing.

9.3.2.2 All surfaces of the examination components should be free of scale, dirt, burrs, slag, spatter, or other conditions that could interfere with the examination results.

9.3.2.3 To make a thickness measurement or scan, the operator places the EMAT probe head on the object to be examined. A trigger pulse is sent to the synchronizer circuit located in the signal processing electronics. Coincident with a leading edge of the digitizer clock, a triggering pulse is sent to the EMAT coil pulser in the probe head to trigger the digitizer board. A large current spike pulse is generated in the transmit

EMAT coil, which, in the presence of the applied magnetic field, launches an ultrasonic shear wave.

9.3.2.4 The shear wave is reflected at the back surface interface and is then detected by the receiver EMAT coil, this being the same coil in a pulse-echo configuration or separate coils in a pitch-catch configuration.

9.3.2.5 The voltage from the receiver EMAT coil is amplified by a low-noise preamplifier and sent to the receiver section in the signal processing electronics, where it is further amplified, filtered, and sent to the waveform digitizer board. The time-of-arrival and amplitude of the digitized signal is measured and used to compute the wall thickness using computer software. The process is repeated for scan mode at fixed time intervals.

9.3.2.6 Periodically check the sensitivity of the equipment by scanning the reference standard. Make these checks prior to any examination, prior to equipment shutdown after examination, and at least every 4 h during continuous equipment operation. Adjust the equipment anytime that a signal varies in sensitivity by 10 % or more from that established initially with the reference standard.

10. Interpretation of Results

10.1 Agreement should be reached between the users of this practice and personnel for whom the ultrasonic examinations are being performed, as applicable, regarding the interpretation of results of the examinations as well as how these results should be recorded. All indications that exceed the rejection level as defined by the material specification or purchase order shall be rejected.

11. Report

11.1 Record the following information at the time of the measurements, and include it in the report:

11.1.1 *Examination Procedure:*

11.1.1.1 Instrumentation description;

11.1.1.2 Standardization blocks, dimensions, flaw descriptions, and material types;

11.1.1.3 Detailed description of the EMAT, including size, frequency, and type; and

11.1.1.4 Scanning method.

11.1.2 *Results:*

11.1.2.1 Indication locations;

11.1.2.2 Thickness measurements; and

11.1.3 Personnel data and certification level.

12. Keywords

12.1 electrically conductive; electromagnetic acoustic transducer; ferromagnetic; flaw detection; nondestructive testing; NDT of weldments; thickness measurements; ultrasonic examination

SUMMARY OF CHANGES

Committee E07 has identified the location of selected changes to this standard since the last issue (E1816 - 07) that may impact the use of this standard. (November 1, 2012)

- (1) Added reference Specification **E543**.
(2) Deleted reference MIL-STD-410, replaced with NAS-410.
- (3) Modified Section 6, Basis of Application, to reflect use of NAS 410 and the inclusion of Specification E543.

ASTM International takes no position respecting the validity of any patent rights asserted in connection with any item mentioned in this standard. Users of this standard are expressly advised that determination of the validity of any such patent rights, and the risk of infringement of such rights, are entirely their own responsibility.

This standard is subject to revision at any time by the responsible technical committee and must be reviewed every five years and if not revised, either reapproved or withdrawn. Your comments are invited either for revision of this standard or for additional standards and should be addressed to ASTM International Headquarters. Your comments will receive careful consideration at a meeting of the responsible technical committee, which you may attend. If you feel that your comments have not received a fair hearing you should make your views known to the ASTM Committee on Standards, at the address shown below.

This standard is copyrighted by ASTM International, 100 Barr Harbor Drive, PO Box C700, West Conshohocken, PA 19428-2959, United States. Individual reprints (single or multiple copies) of this standard may be obtained by contacting ASTM at the above address or at 610-832-9585 (phone), 610-832-9555 (fax), or service@astm.org (e-mail); or through the ASTM website (www.astm.org). Permission rights to photocopy the standard may also be secured from the ASTM website (www.astm.org/COPYRIGHT).